

proudly
brought
to you by



2026

Section: 21 Craft

Forms & Fees Due

Tues. 23rd June 4pm

Exhibits Due

Wed. 24th June 4pm

Judging

Sat. 27th June 11am



**Monday 29th &
Tuesday 30th June**



FOLLOW US

www.athertonshow.com.au



General Conditions & Competition Rules

- Rules & Entry Fees for all exhibitors shall be as per the schedule.
- No late entries will be accepted.
- Entry Fees are not refundable.
- All Horses must be Hendra vaccinated to camp on the Atherton Showgrounds
- No article is to be entered in more than one (1) Class.
- Sale of Exhibits: Details of potential buyers will be forwarded to the exhibitor.
- Exhibits may not be collected until after 4pm on the last day of Show, and then only under Steward's supervision.
- Exhibitors please advise the Show Office or the Stewards of any entries entered but not delivered for judging.
- If the merit of the exhibits in any Class or Championship is not, in the opinion of the Judge, sufficient to entitle them to a Prize, the Judge may withhold prizes
- A competition is defined as there being more than one competitor or entrant, with the preference being a minimum of three (3) competitors.
- In the event of there being no competition in a Class, any or all Prizes may be withheld.
- In the event of a draw for placing of exhibits by the judge, preference is that clear single place holders be chosen by whatever means. If the placing must be shared, the total Prize money for the Class must remain the same and the number of placeholders is to remain the same. The Prize money to be shared is added together and then split evenly between the winners. The next placing is then omitted. For example, if there is a draw between two exhibits for 1st place, 2nd place is omitted and the Prize money from 1st and 2nd is added together and divided evenly between the two winners. 3rd place is then awarded as usual, if applicable.
- Locally made or grown, to be construed as meaning exhibits from districts included in the Tableland Regional, Mareeba, Cairns Regional and Cassowary Coast Shires, unless otherwise stated.
- No Exhibitor will be allowed to display, at the current Show, ribbons, place-cards or awards won at any other show.
- For use on waybills, the PIC No for the Atherton Showgrounds is QIAE0505.
- All entries in livestock must be a bona fide property of the Exhibitor 30 days prior to the show, unless otherwise stated, and he or she makes affidavit that the property is his or her property on request.
- All livestock must be guaranteed free from disease or ticks.
- Necessary attendants for stock will be furnished with Special Passes upon applying to the Secretary's Office.
- No Exhibitor shall be permitted to remain in the exhibition area or with the Stewards or Judges during the time of judging.
- No unauthorized Exhibitor or Visitor will be admitted to the Ring during any event.
- The Society reserves the right to substitute Prizes or trophies donated after printing the Schedule in lieu of Prize money.
- All **Prize** money will be paid on the days of the Show at the Secretary's Office or the Show Ring Office. Photo ID or letter of authority must be presented to collect Prize money Prize money \$100 and over is required to make a direct deposit to a nominated bank account. All Prize monies over the amount of \$10.00 not collected prior to the end of September will be deposited to the nominated bank account by electronic transfer. Any smaller amounts, or Prize money where no bank account has been nominated, will be deemed a donation to the Society.
- Stewards are empowered to act as they think fit in all cases of cruelty to exhibits.
- Any person, whether an Exhibitor or otherwise, who makes use of foul or abusive language on the grounds or in the hall, will incur a penalty of expulsion, or be dealt with as the Committee may determine.
- The foregoing rules and regulation, and the notes as set forth in the Schedule are to be the conditions of the competition. Any matter arising not specially provided for in the foregoing shall be determined by the Committee, whose decision is final.
- In the event of an accident requiring the service of an Ambulance this Society or any person associated with the Society will not be responsible for any charges.
- Doping: It is forbidden to use or administer or cause to be used or administer on or to any animal, any tranquilizer, stimulant, depressant or drug of any kind, in any manner whatsoever, either before the commencement of or during any Show activity or competition. Any person owning, riding or entering an animal in any such activity or competition shall, at the discretion of the Stewards, be liable for disqualification for a period of up to five (5) years. The certificates of a qualified veterinary surgeon to such effect shall be prima facie evidence that any such tranquillizer, stimulant, depressant or drug has been used or administered. If during any Show activity, it is necessary to treat an animal with a drug that is calming, anti-tetanic, fortifying or stimulating, a veterinary surgeon appointed by the Stewards must be notified immediately and they must verify the expedience of necessity of the treatment to be given.
- Perpetual Trophies will be presented at the event for photographs and is NOT under any circumstances to be removed from the Atherton Showgrounds. Perpetual Trophies always remain the property of Atherton Tableland Agricultural Society. Atherton Show Society will have the trophy engraved and stored at the Show Office. A keeper trophy will be presented. If you require any further photos after the event, please contact the Atherton Show Office.

PLEASE ALSO REFER TO QUEENSLAND AG SHOWS RULES
SOCIETIES, STEWARDS, JUDGES, EXHIBITORS AND COMPETITORS AT AGRICULTURAL SHOWS.
AVAILABLE FOR DOWNLOAD AT qldagshows.com.au



How to Enter the Show

GENERAL INFORMATION FOR ALL SECTIONS OF THE ATHERTON SHOW

1. Reading the Schedule
2. Completing your entry form
3. Closing Dates
4. Labelling your Exhibit
5. Collecting your exhibits and Prize money

1. Reading the Schedule

- a. The schedule is broken down into three levels: Sections, Subsections and Classes. For example, Photography is a Section, Colour Prints is a Subsection, and Landscape is a Class. Only Sections and Classes have numbers that you will use on your Entry Form.
- b. Carefully read all the closing dates and conditions of entry at the beginning of your section.
- c. Find the Class that best suits or describes your exhibit.
- d. Contact the Show Office if you need any help with classifying your exhibit. If we can't help, we will get in touch with one of the Stewards.

2. Completing your entry form – enter online

- a. Entries are preferred online via:
Website at www.athertonshow.com.au -> Competitions -> Sections & Forms
<https://showday.online/>
- b. Most sections will just use a General Entry form, but the following sections have their own specific forms:
Horses, Beef Cattle, Poultry, Agriculture and Floriculture
- c. You need to use a separate entry form for each person exhibiting, but you can use the same General Entry form for more than one section.
- d. In the Schedule, find the Section No at the start of each section and write just the number in the column, (e.g. Art is Section 20)
- e. Find the Class No in the Schedule and write just the number in the column, (e.g. Open Painting – Traditional Techniques is Class 20001)
- f. Briefly describe your exhibit. In some sections, the Class name will be the enough description (e.g. in Poultry: Australian Game Hen), but in other sections it may help Show staff to recognize your exhibit. For example, in Photography your description might be 'Rolling Hay Fields'.
- g. Find the Entry Fee and write it in dollars and cents (0.50) in the column. The Entry Fees can often be found under the Subsection heading, but if there is no Entry Fee noted there, use the fee shown at the beginning of the Section.

3. Closing Dates

- a. There are two important Closing Dates for each Section.
~ Forms & Fees due: This is the last date your Entry Form and Entry Fee can be received by the Show Office, either in person, by post, or by email with an electronic payment.
~ Deliver Exhibits: This is the latest time and day that your exhibit can be received by the Show Office or Stewards. Note: In some section forms, fees and exhibits are all due at the same time.
- b. You don't need to wait until the last day. The last day is often the busiest and you will wait longer to be served.
- c. We take entries from the 1st of March. If you are going away, you can arrange for an earlier drop-off.

4. Labelling your Exhibit

- a. When you bring your Entry Form and/or exhibit into the Show Office, Class Cards will be issued for all the pavilion exhibits.
- b. Class Cards are a double ticket which is torn into two identically marked pieces. Each piece shows the Section and class Number, and a unique Exhibit No.
- c. This Exhibit No is used for identification and tracking of each exhibit and to ensure that items are returned to the correct owner. The Judges also use this number to nominate place-winners.
- d. One side of the Class Card will be attached to your exhibit in clear view for the Judge. The other side stays with you, the entrant, and is used for collecting the item after the Show.
- e. Make sure your name is on your items, but not somewhere it can be seen by the judge. If your name can be seen, the Stewards will have to cover it, and it may detract from the presentation of your exhibit.

5. Collecting your exhibits and Prize money

- a. All exhibits must stay on display until 4pm Show Tuesday afternoon. Prize money may be picked up from the show office after 4pm on the Monday. Stewards will only be available to return your exhibit from 4pm to 6pm on the Tuesday after show. This is the busiest time for people to collect their items and prizes.
- b. If you can wait, the Show Office is open 9am-5pm for the 3 days (Wed-Fri) following the Show and there is often someone available by arrangement in the following week.
- c. You must have the stub of your Class Cards to be able to collect your items, and the Stewards or Show staff will check the exhibits back out to you.
- d. No exhibitors are allowed to take exhibits out of the display area. Identification must be shown when collecting Prizes and Prize money. A Medicare card can be used as identification for children.
- e. If you want someone else to collect your Prizes, you will need to send them with a letter of authority from you and they will need to show their ID when they collect for you.
- f. Prize money over \$100 will be paid by direct deposit in accordance with the Queensland Government Laws and Regulations for Associations.

Section: 21 - Craft

STEWARDS: Amanda Saunders, Helen Baty

ENTRY FEE: As stated below

ENTRIES FORMS

& FEES DUE: Tuesday 23rd June 4pm

DELIVER EXHIBITS: Before 4pm Wednesday 24th June

JUDGING STARTS: 11 am Saturday 27th June

CONDITIONS OF ENTRY:

- Refer General Conditions of Entry & Show Rules.
- All work must have been executed by the Exhibitor.
- Class Cards are to be clearly displayed on the front of exhibits.
- All exhibits must not have been previously entered in the Atherton Show in any section.
- Entry Form to clearly state type of article and dominant material used.
- Where there are three (3) or more exhibits in Any Other Variety Classes by different exhibitors, a special Class may be provided at the discretion of the stewards and committee.
- In the event of a tie-on points an independent Judge from another section will be requested to act as an arbitrator.
- Exhibitors please advise the Show Office, or the Stewards of any exhibit entered but not delivered for judging.
- Rustic is defined as being simple & unsophisticated and/or made of rough or irregular timbers.
- Scrapbooking exhibits are permitted if they have been crafted in a specialty Class.
- Kit classes are not eligible for Champion Prizes.



Men's Shed Competition

Entry Fee: \$5

Prize \$100.00, Trophy

The winning Men's Shed gets to select the item for the 2027 Competition

Class 21018 Men's Shed Competition

The 2026 Men's Shed competition item is "The Box"— chosen by the Men's Shed winners of the 2025 Atherton Show.

The general rules that apply to the Men's Shed entry are:

Open to all Men's Shed North of Cardwell.

Original Work

Your entry must be the original work of the Men's Shed team/person submitting it — not previously entered in this Show.

Correct Item

You must build the design required for 2026 as shown below. Item can be a:

- * Toy Box
- * Blanket Box
- * Toolbox
- * Any box

The sizes indicated are the maximum size the box can be smaller (not larger)

- * Box must be hinged and have a hasp
- * Any type of wood can be used
- * The Box can include drawers, trays, dividers etc.

Number of Entries

Each Men's Shed can submit up to 3 entries.

Entries can be advertised for sale after judging is completed.

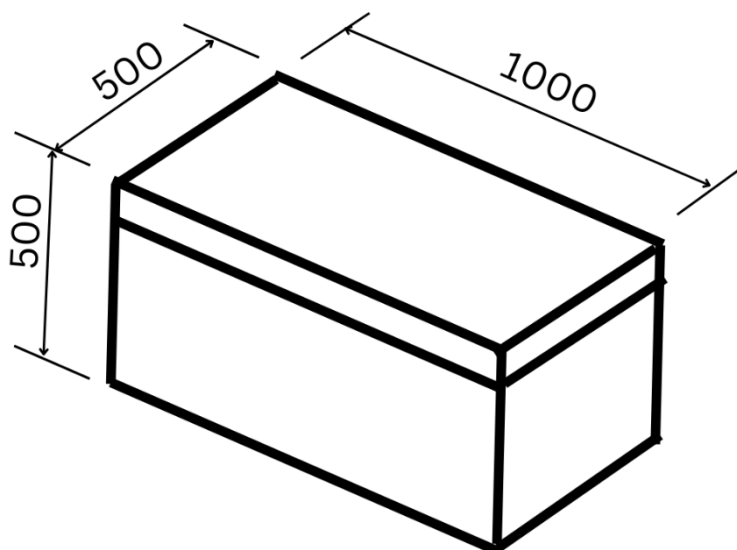

Woodwork

Open

Entry Fees: \$5.00

Prizes: 1st: \$50.00, 2nd: \$25.00

Class 21001 Furniture, Machined/Turned
Any Article

Class 21002 Furniture
Any article

Class 21003 Wood Burning
Any article

Class 21004 Wood Carving
Any Article

Class 21005 Rustic
Any item

Class 21006 Any other Article

Class 21007 Segmented

Class 21008 Intarsia Wood Working

Class 21009 Woodwork – Turned

Novice

Entry Fees: \$3.00

Prizes: 1st: \$30.00, 2nd: \$20.00

Class 21010 Novice Woodwork – Furniture

Class 21011 Novice Woodwork - Wood Burning

Class 21012 Novice Woodwork - Wood Carving

Class 21013 Novice Woodwork - Any Other Article

Primary School

Entry fee: \$2.00

Prizes: 1st: \$15.00, 2nd: \$10.00

Class 21014 Primary School Any Article Turned

Class 21015 Primary School Any Other Article

Secondary School

Entry Fee: \$3.00

Prizes: 1st \$20.00, 2nd \$10.00

Class 21016 Secondary School Any Article Turned

Class 21017 Secondary School Any Other Article

Woodwork Special Prizes

Champion Woodwork

Prize: \$50.00, Rosette, Perpetual Trophy

Reserve Champion Woodwork

Prize: \$20.00, Rosette

Champion Woodwork – Junior Overall

Prize: \$50.00, Rosette

Most Innovated Woodwork – LA Croft Memorial

Prize: Rosette, Perpetual Trophy

Metalwork

Open

Entry Fees: \$5.00

Prizes: 1st \$50.00, 2nd \$25.00

Class 21101 Metal Art - Any Article

Class 21102 Metal Fabrication - Any Article

Class 21103 Metal Machining - Any Article

Primary School

Entry Fees: \$1.00

Prizes: 1st \$10.00, 2nd \$5.00

Class 21107 Primary School Metal Art - Any article

Class 21108 Primary School Metal Fabrication - Any Article

Class 21109 Primary School Metal Machining- Any Article

Novice

Entry Fees: \$3.00

Prizes: 1st \$30.00, 2nd \$20.00

Class 21104 Novice Metalwork - Metal Art

Class 21105 Novice Metalwork – Fabrication

Class 21106 Novice Metalwork – Machining

Secondary School

Entry Fees: \$2.00

Prizes: 1st \$20.00, 2nd \$10.00

Class 21110 Secondary School Metal Art - Any Article

Class 21111 Secondary School Metal Fabrication - Any Article

Class 21112 Secondary School Metal Machining - Any Article

Metalwork Special Prizes

Champion Metalwork

Prize: \$50.00, Rosette

Reserve Champion Metalwork

Prize: \$20.00, Rosette

Champion Metalwork - Junior

Prize: \$50.00, Rosette

Fibre Craft

Entry Fee: \$1.00

Prizes: 1st \$10.00, 2nd \$5.00

Samples of original fiber are required. Skeins to be minimum 30g & accompanied by a 10cm minimum knitted, crocheted or woven square.

Class 21201 Book - Hand Bound

Class 21202 Paper - Hand Made

Class 21203 Textile Dyed

Class 21204 Textile Felted

Class 21205 Textile surface/Woven design

Class 21206 Yarn, hand spun skein of 100% natural fibre - 30gm sample

Class 21207 Yard, hand spun skein of creative fibre - 30gm sample

Class 21208 Any other Fibre Craft

Class 21209 Fibre Art

Fiber art is a form of fine art that utilises natural or synthetic fibers to create aesthetic and expressive works, emphasising artistic value over utility.

**Best Fibre Craft
Prize: Ribbon**

Scrapbooking

Entry Fee: \$1.00

Prizes: 1st \$10.00, 2nd \$5.00

Class 21301 Single page - any technique
Exhibits size 30cm x 30cm

Class 21302 Monochrome Page
Exhibit size 30cm x 30cm
- any technique with black and white photo

Class 21303 Double Page
multiple techniques (minimum 5) containing more than 5 photographs.

**Best Overall Scrapbooking
Prize: Ribbon**

Paper Crafts

Entry Fee: \$1.00

Prizes: 1st \$10.00, 2nd \$5.00

Class 21401 Paper Tole, any medium
Paper Tole, any medium - Min six level. Must be suitably wired and framed.

Class 21402 Paper Quilling

Class 21403 Paper Craft, Gift Project, Open Medium.

Class 21404 Paper Art, Open Style, Open Medium - 2 dimensions

Class 21405 Paper Art - any technique - 3 dimensions

Class 21406 Any other article not specified e.g. origami

**Best Paper Craft
Prize: Ribbon**

Special Interest Crafts - Open

Entry Fee: \$1.00

Prizes: 1st \$10.00, 2nd \$5.00

Class 21501 Card Making

Class 21502 Toy - Material - Suitable for children

Class 21503 Diamond Dots

Class 21504 Jewellery - Home-Made - mount on cardboard

Class 21505 Bear & Doll Making - any article

Class 21506 Bead Work - Excluding Jewellery.

Class 21507 Article Made from Waste Material.

Class 21508 Macrame

Class 21509 Residential Aged Care Craft - any article

Class 21510 Any other handicraft not specified

Class 21511 Indigenous craft - any medium, any subject

**Best Special Interest Craft
Prize: Ribbon**

Primary School Craft

Entry Fee: \$0.50

Prizes: 1st \$5.00, 2nd \$3.00

Class 21601 Lego Construction Kit - Any Article

Not eligible for champion prizes

Class 21602 Lego Construction: Own Creation - Any Article

Class 21603 Construction - Any Article

Class 21604 Article Made from Waste Material

Class 21605 Toy – Fabric

Class 21606 Paper Craft

including paper mache and origami

Class 21607 Colouring-In

Class 21608 Felting

Class 21609 Any Other Handicraft Not Mentioned

Class 21610 Graffiti Name Fence – Special Class
Prize: 1st \$25.00, 2nd \$15.00, 3rd \$10.00

The fence is to be no longer than 30cm and can be made out of any materials such as paddle pop sticks and foam. The fence must be free standing.

Best Primary School Craft

Prize: Ribbon

Secondary School Craft

Entry Fee: \$1.00

Prizes: 1st \$10.00, 2nd \$5.00

Class 21701 Lego Construction Kit - any article

Not eligible for champion prizes.

Class 21702 Lego Construction - Own creation, any article

Class 21703 Construction - any article

Class 21704 Article made from waste material

Class 21705 Toy – fabric

Class 21706 Paper Craft - e.g. origami

Class 21707 Any other handicraft not mentioned

Class 21708 Clock – Special Class

Prize: 1st \$50.00, 2nd \$30.00, 3rd \$20.00

Goal: Craft a working clock using (non) traditional or recycled materials.

Materials: Use any combination of items you have at home - cardboard, plastic bottles, old CD's, metal scraps, fabric, clay, wood pieces, etc.

Time mechanism: Use a real clock mechanism from an old clock or buy a new mechanism from the Show Office.

Design requirements: Must include numbers or time indicators (e.g. Roman numerals, symbols, or abstract art) Must have a face and at least one clock hand.

Creativity counts more than precision.

Best Secondary School Craft

Prize: Ribbon

Special Prizes

Judges Encouragement Award

Prize: Trophy

Champion Junior Craft of Show

Michael Neil Brander Award – Best Junior Classes

Prize: \$20.00, Rosette



Edna Beazley Memorial Participation Award

Prize: \$100

Since 1964, Edna Beazley had entered her creations in classes across many sections from needlework to craft. In 2017, Edna was recognised for her work and continued support of the Atherton Show.

The Edna Beazley Participation Award is awarded to the Exhibitor with the highest number of points from classes in the following sections:

- * 17 Needlework
- * 19 Photography
- * 20 Art
- * 21 Craft

Points awarded:
1st - 3 points, 2nd - 2 points, 3rd - 1 point
Champion - 3 points, Reserve Champion - 2 points



Shirley Pink Memorial Participation Award

Prize: \$100

Shirley Pink was an active long term member of the Atherton Show Society and a life member from 1971. Over the many years of bringing the show to town along side her husband RJ 'Tom' Pink, also a life member and former Secretary of the Atherton Show, Shirley would admire all the exhibits in the Pavilion.

The Shirley Pink Participation Award is awarded to the Exhibitor with the most entries all sections in the Pavilion with 1 point awarded for each exhibit entered.

Sections included:

- * 11 Agriculture
- * 12 Floriculture
- * 13 Orchids
- * 14 Floral Art
- * 15 Culinary Art
- * 17 Needlework
- * 19 Photography
- * 20 Art
- * 21 Craft



the
Atherton
show

2026

29TH & 30TH JUNE



FIELDS OF THE FUTURE

INNOVATE • CULTIVATE • CELEBRATE